



## Optimization of Perturb and Observe Algorithm Efficiency in MPPT PV Array System Using Boost Converter: A Simulink-Based Investigation Prior to PLC Monitoring System Integration

Abdillah Aziz Muntashir<sup>1</sup>, Lin Prasetyani<sup>2</sup>, Surawan Setiyadi<sup>3</sup>, M. Irkam Baihaqi<sup>4</sup>

<sup>1-4</sup>Teknik Mesin Industri/Mechatronics, Politeknik Astra, Indonesia, 17530

[lin.prasetyani@polytechnic.astra.ac.id](mailto:lin.prasetyani@polytechnic.astra.ac.id)

<https://doi.org/10.37339/e-komtek.v9i2.2769>

Published by Politeknik Piksi Ganesha Indonesia

### Abstract

#### Artikel Info

Submitted:

03-10-2025

Revised:

24-10-2025

Accepted:

28-10-2025

Online first:

31-12-2025

The increasing demand for renewable energy necessitates efficient power-conversion and control strategies to maximize the utilization of photovoltaic (PV) systems. Among various approaches, Maximum Power Point Tracking (MPPT) is critical in ensuring optimal energy extraction under varying irradiance and load conditions. This study focuses on optimizing the efficiency of the Perturb and Observe (P&O) algorithm implemented in a PV array system with a DC-DC boost converter. A comprehensive Simulink-based investigation is conducted to analyze the algorithm's performance with respect to tracking speed, stability, and steady-state oscillation. The results demonstrate that the optimized P&O method significantly improves the boost converter's dynamic response while maintaining high tracking accuracy under irradiance fluctuations and load variations. Furthermore, this work is presented as a preliminary study preceding the integration of MPPT control with a PLC-based monitoring system, thereby providing a reliable foundation for real-time industrial applications. The findings contribute to improving PV system efficiency and provide valuable insights for future implementation in smart energy management platforms.

**Keywords:** Photovoltaic; MPPT; Perturb and Observe (P&O); Boost converter; MATLAB/Simulink; PLC monitoring

### Abstrak

Meningkatnya kebutuhan terhadap energi terbarukan menuntut adanya strategi konversi daya dan kontrol yang efisien untuk memaksimalkan pemanfaatan sistem fotovoltaik (PV). Di antara berbagai pendekatan, Maximum Power Point Tracking (MPPT) menjadi faktor penting dalam memastikan ekstraksi energi optimal pada kondisi iradiasi dan beban yang bervariasi. Penelitian ini berfokus pada optimalisasi efisiensi algoritma Perturb and Observe (P&O) yang diimplementasikan pada sistem PV array dengan konverter DC-DC tipe boost. Investigasi berbasis Simulink dilakukan untuk menganalisis kinerja algoritma dalam hal kecepatan tracking, stabilitas, serta osilasi pada keadaan tunak. Hasil penelitian menunjukkan bahwa metode P&O yang telah dioptimalkan mampu meningkatkan respon dinamis konverter boost sekaligus mempertahankan akurasi tracking yang tinggi pada kondisi fluktuasi iradiasi maupun variasi beban. Selain itu, penelitian ini disajikan sebagai studi awal sebelum integrasi kontrol MPPT dengan sistem monitoring berbasis PLC, sehingga dapat menjadi landasan yang andal untuk aplikasi industri secara real-time. Temuan ini berkontribusi terhadap peningkatan efisiensi sistem PV dan memberikan wawasan yang berharga untuk implementasi selanjutnya pada platform manajemen energi cerdas.

**Kata-kata kunci:** photovoltaik (PV), MPPT, Perturb and Observe (P&O), Boost, MATLAB/Simulink



This work is licensed under a Creative Commons Attribution-NonCommercial 4.0 International License.

## 1. Introduction

The increasing global demand for renewable energy has placed photovoltaic (PV) systems at the forefront of sustainable electricity generation. PV arrays, however, are characterized by nonlinear current–voltage (I–V) and power–voltage (P–V) characteristics, which are highly sensitive to irradiance and temperature variations [1], [2]. These fluctuations reduce conversion efficiency and hinder the reliability of PV-based power systems. To overcome this challenge, Maximum Power Point Tracking (MPPT) techniques have been widely employed to ensure that PV systems consistently operate at or near their maximum power point [3].

Among various MPPT approaches, the Perturb and Observe (P&O) algorithm remains the most widely used due to its simplicity and low computational cost [4], [5]. However, the conventional P&O method suffers from steady-state oscillations and slow tracking speed under rapidly changing irradiance conditions [4], [6], [7]. Recent studies have proposed enhancements to P&O, such as adaptive step size [8], fuzzy-based modifications [9], and hybrid techniques [10], with simulation and experimental validations demonstrating improved efficiency. Most of these implementations employ DC–DC boost converters as the interfacing circuit due to their ability to step up voltage and maintain stability under load changes [11], [12].

Several simulation-based investigations have been conducted using MATLAB/Simulink to analyze P&O with boost converters under varying irradiance and load conditions. For example, Tan et al. [13] proposed an MPPT method that adjusts duty cycle based on power and voltage fluctuations, while Jana et al. [14] examined the dynamic behavior of a boost converter-based PV system under input and load deviations. Krishnaram et al. [15], [16] optimized P&O using an ANN-supported control under partial shading, and Singh et al. [17] compared different MPPT techniques for convergence performance under meteorological variations. In addition, studies by Noman et al. [18] analyzed boost converter conduction modes and shading impacts, respectively, providing insights into duty cycle optimization under real operating conditions. Although these works demonstrate improved PV tracking efficiency, they primarily focus on algorithmic enhancements or converter design in isolation.

Despite extensive progress in the optimization of P&O algorithms and boost converter design, limited attention has been given to preparing these algorithms for integration with real-time monitoring systems such as Programmable Logic Controllers (PLCs) [19], [20]. Existing studies are often limited to simulation-based analysis without considering the constraints and

requirements of industrial monitoring and control platforms [21], [22]. This paper aims to address this gap by conducting a Simulink-based investigation on the optimization of P&O efficiency in a PV array system using a boost converter, with a particular focus on dynamic performance under irradiance fluctuations and load variations. The novelty of this study lies in the optimization of the P&O algorithm using an adaptive perturbation mechanism specifically designed as a preparatory step for PLC-based industrial monitoring integration—an aspect that has not been addressed comprehensively in previous simulation-only approaches.

## 2. Method

The methodology of this study is designed to evaluate the performance of the Perturb and Observe (P&O) MPPT algorithm applied to a photovoltaic (PV) system using a DC–DC boost converter. The workflow consists of four major steps: (1) modeling the PV array based on the manufacturer’s datasheet, (2) designing the boost converter, (3) implementing the P&O algorithm, and (4) testing the integrated system in MATLAB/Simulink under varying irradiance and load conditions. The PV module selected for this study is the 1Soltech 1STH-215-P, whose electrical specifications are presented in Table 1. These values were incorporated into the PV model block within Simulink to replicate the performance of a single module under standard test conditions (STC).

**Table 1.** Electrical PV Module Specifications (1Soltech 1STH-215-P)

Module Data	
Module	1Soltech 1STH-215-P
Maximum Power (W)	213.15
Open circuit voltage Voc (V)	36.3
Voltage at maximum power point Vmp (V)	29
Temperature coefficient of Voc (%/°C)	-0.36099
Cells per module (Ncell)	60
Short-circuit current Isc (A)	7.84
Current at maximum power point Imp (A)	7.35
Temperature coefficient of Isc (%/°C)	0.102

To achieve the required voltage and current levels, the PV array was configured as 2 modules connected in series per string, and 2 strings connected in parallel (2S2P). The current–voltage (I–V) and power–voltage (P–V) characteristics are generated in MATLAB/Simulink using these parameters. Irradiance and temperature variation blocks are used to simulate real environmental changes. The parameters of the single-diode model used in the Simulink

implementation are summarized in **Table 2**. These were integrated to capture the nonlinear behavior of the PV array under varying irradiance and temperature.

**Table 2.** PV Model Parameters

Model Parameters	
Light-generated current $I_L$ (A)	7.8649
Diode saturation current $I_0$ (A)	2.9259e-10
Diode ideality factor	0.98117
Shunt resistance $R_{sh}$ (ohms)	313.3991
Series resistance $R_s$ (ohms)	0.39383

A DC–DC boost converter is used to regulate the output voltage of the PV module. The design equations for the inductor and capacitor are given as:

$$L = \frac{V_{in} \cdot D}{\Delta I_L \cdot f_s} \quad \dots 1)$$

$$C = \frac{I_o \cdot D}{\Delta V_o \cdot f_s} \quad \dots 2)$$

where  $V_{in}$  is the input voltage from the PV array,  $D$  is the duty cycle,  $\Delta I_L$  is the allowable ripple current,  $f_s$  is the switching frequency,  $I_o$  is the output current, and  $V_o$  is the permissible output voltage ripple. The boost converter is implemented in Simulink with an IGBT/MOSFET as the switching device and a PWM generator to control duty cycle adjustments. Figure 1. Boost converter schematics the author’s use.

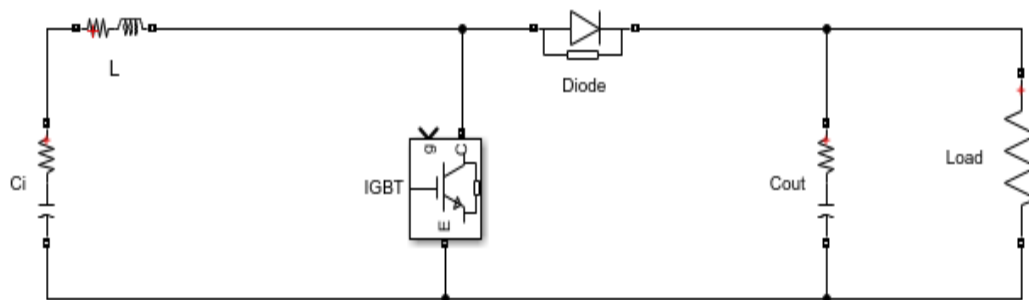

**Figure 1.** Boost converter schematics

The Perturb and Observe (P&O) algorithm is implemented to continuously adjust the boost converter's duty cycle. At each iteration, the PV output power is measured and compared with the previous value. If the power increases, the duty cycle is perturbed in the same direction; otherwise, the perturbation reverses direction. The algorithm is coded using MATLAB Function

blocks in Simulink, with a sampling time that ensures fast dynamic response while minimizing oscillations at the maximum power point.

**Table 3.** Boost Converter Specification

Input capacitance (C <sub>i</sub> )	100 × 10 <sup>-6</sup> F
Input Resistance (R <sub>i</sub> )	0.0001 Ω
Inductance (L) in inductive filter	2 × 10 <sup>-3</sup> H
Resistance (R) in inductive filter	0.1 Ω
Capacitance of capacitive filter (C <sub>i</sub> )	100 × 10 <sup>-6</sup> F
Resistance of capacitive filter (R)	0.0001 Ω
Load resistance (R)	20 Ω

Simulations are performed in MATLAB/Simulink with the following conditions (1). Irradiance levels: 200 W/m<sup>2</sup> to 1000 W/m<sup>2</sup> (step changes); (2). Temperature: 25 °C to 45 °C; (3). Load resistance: variable to evaluate dynamic performance. The simulation environment integrates the PV model, boost converter, and P&O controller. Measurements are taken for output power, voltage, current, and duty cycle dynamics. The performance metrics evaluated in this study include tracking efficiency: ratio of extracted power to theoretical maximum power, and comparing the results with and without the P&O Algorithm. This methodological framework provides a reliable foundation for subsequent integration with a PLC-based monitoring system, ensuring that the optimized algorithm is suitable for real-time industrial applications.

In this work, the conventional P&O algorithm was improved through an adaptive step-size strategy. The perturbation step ( $\Delta D$ ) dynamically varies based on the rate of change in power ( $\Delta P/\Delta V$ ). When the PV operating point is far from MPP (large  $\Delta P$ ), a larger perturbation step is applied to accelerate tracking. Conversely, near the MPP (small  $\Delta P$ ), the step size is automatically reduced to suppress steady-state oscillations. The adaptive scaling factor is expressed as:

$$\Delta D(k) = K \cdot \frac{|P(k) - P(k-1)|}{P(k)}$$

where  $K$  is a constant tuning factor. This enhancement allows faster dynamic response while maintaining high stability at steady state.

### 3. Results and Discussion

The proposed PV array system configured in 2S2P (four modules of 1Soltech 1STH-215-P) was implemented in MATLAB/Simulink. The system includes the PV array, a DC–DC boost converter, and the Perturb and Observe (P&O) MPPT algorithm. The boost converter duty cycle was dynamically adjusted based on the MPPT control signal to ensure operation at the maximum power point—figure 2. Simulation Setup implemented in MATLAB/Simulink.

This configuration allows the simulation to replicate the interaction between PV generation, converter dynamics, and MPPT control logic, thereby providing a realistic representation before integration with a PLC-based monitoring system. The overall simulation model is constructed in MATLAB/Simulink and consists of several main components that represent the real PV energy conversion process. The PV array block provides the power output based on irradiance and temperature variations, configured in a 2S2P module arrangement according to the specifications in Table 1 and Table 2.

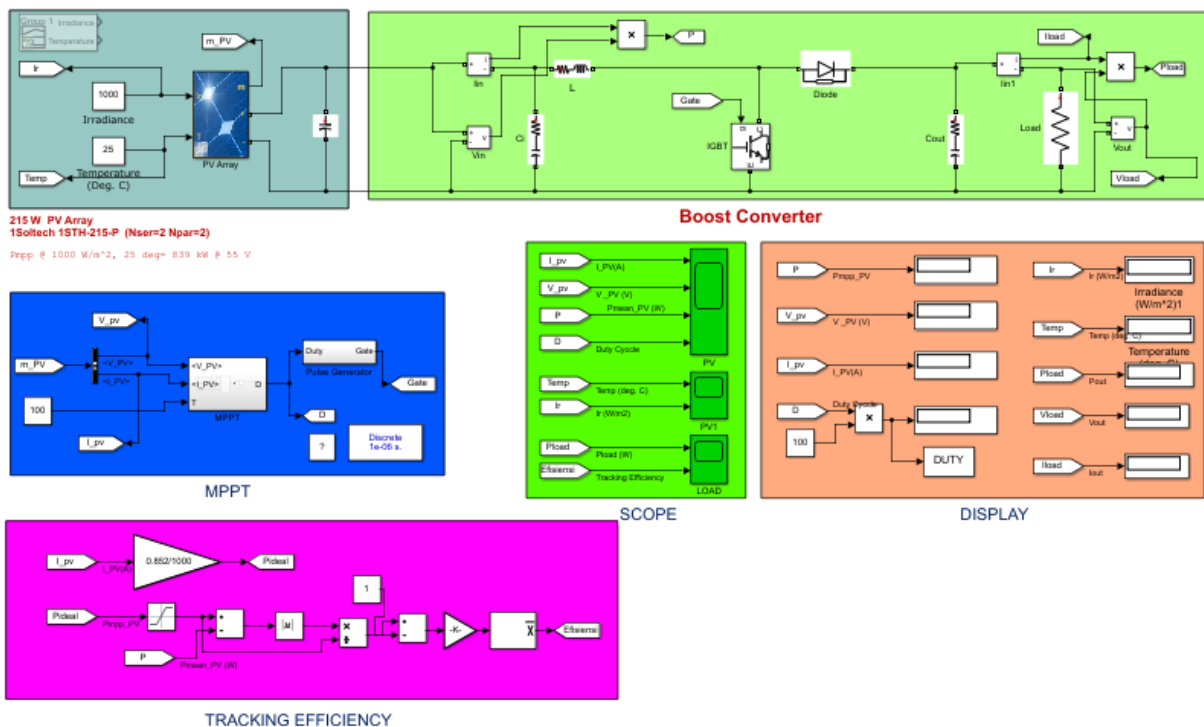
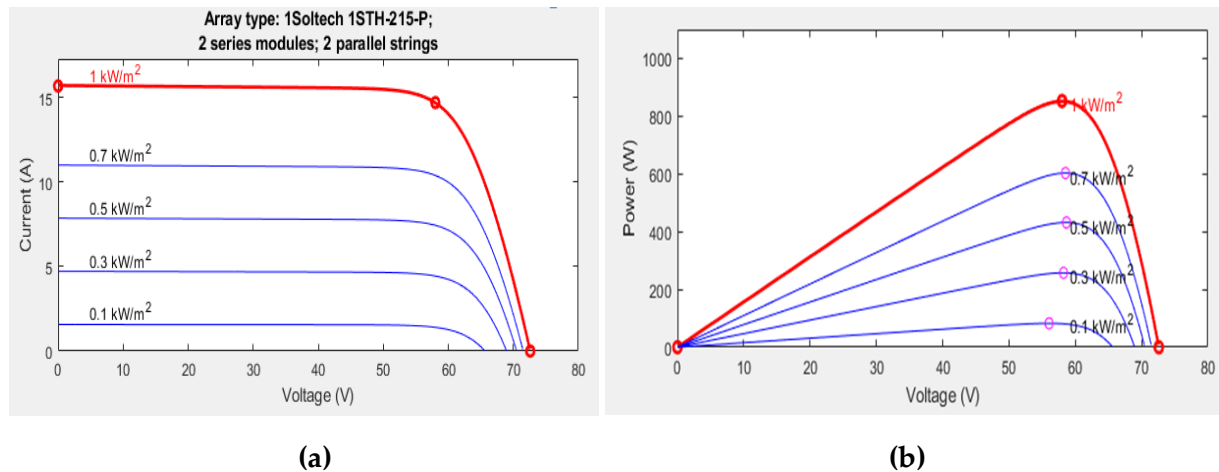

Figure 2. Simulation Setup implemented in MATLAB/Simulink.

This output is connected to a DC–DC boost converter (with an algorithm), which steps up the voltage to a higher, more stable level suitable for system operation. The Perturb controls the boost converter and Observe (P&O) MPPT algorithm, which continuously adjusts the duty cycle to ensure maximum power point tracking. System performance is monitored using Scopes to

visualize dynamic waveforms of voltage, current, and power, while Displays display steady-state measurement values. Additionally, an efficiency-tracking block is included to evaluate the MPPT's effectiveness in extracting maximum power under varying irradiance and duty-cycle conditions.

**Figure 3** presents the I–V and P–V characteristics of the PV array under varying irradiance at a constant temperature of 25 °C. The results demonstrate that the model accurately reflects the effect of irradiance changes and serves as a reliable basis for evaluating the performance of the Perturb and Observe (P&O) MPPT algorithm with a boost converter. As shown in **Figure 3(a)**, the short-circuit current ( $I_{sc}$ ) rises markedly with increasing irradiance, while the open-circuit voltage ( $V_{oc}$ ) shows only minor variation. This trend aligns with the theoretical behavior of PV modules, where irradiance primarily affects current generation through photon absorption. **Figure 3(b)** illustrates the P–V curve, indicating that the maximum power point (MPP) shifts upward with higher irradiance, leading to greater power output, while the corresponding voltage at MPP remains relatively stable with only slight changes.

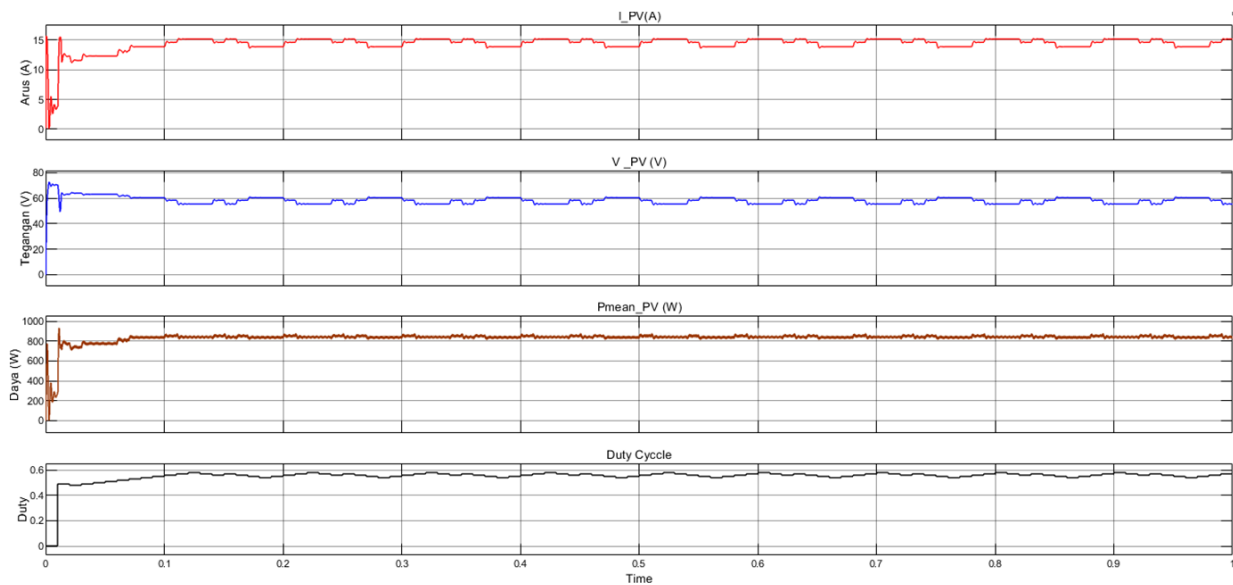

**Figure 3 (a).** shows the I–V curve, **(b).** presents the P–V curve

To further evaluate the MPPT performance, the simulation results at irradiance of 1000 W/m<sup>2</sup> and constant temperature of 25 °C are presented in **Figure 4**. The figure shows the dynamic response of the PV system, including the output voltage, current, and power achieved by the Perturb and Observe (P&O) algorithm. Under a step change in irradiance from 600 W/m<sup>2</sup> to 1000 W/m<sup>2</sup>, the tracking efficiency reaches 99.3% within approximately 0.05 s. The steady-state error in power estimation remains below 1.2%, demonstrating stable maximum power point convergence.

**Table 3.** Electrical PV Module Specifications (1Soltech 1STH-215-P)

Method	Achieved Power (W)	Maximum Tracking Efficiency (%)	Response Time (ms)	Steady-State Oscillation
Without MPPT	600–750	70–85%	–	High
Conventional P&O ( <i>baseline</i> )	~820	96%	80	Moderate
Proposed Optimized P&O	848–852	98–100%	50	Low



**Figure 4.** Shows the Current–Voltage (I–V) Curve

The power curve confirms that the boost converter, under the control of the optimized P&O algorithm, can maintain the system at its maximum power point with only small oscillations, as well as the tracking efficiency shown in [Figure 5](#). The tracking efficiency curve illustrates the algorithm's effectiveness in extracting power, which rises rapidly to near 100% within a short transient period.

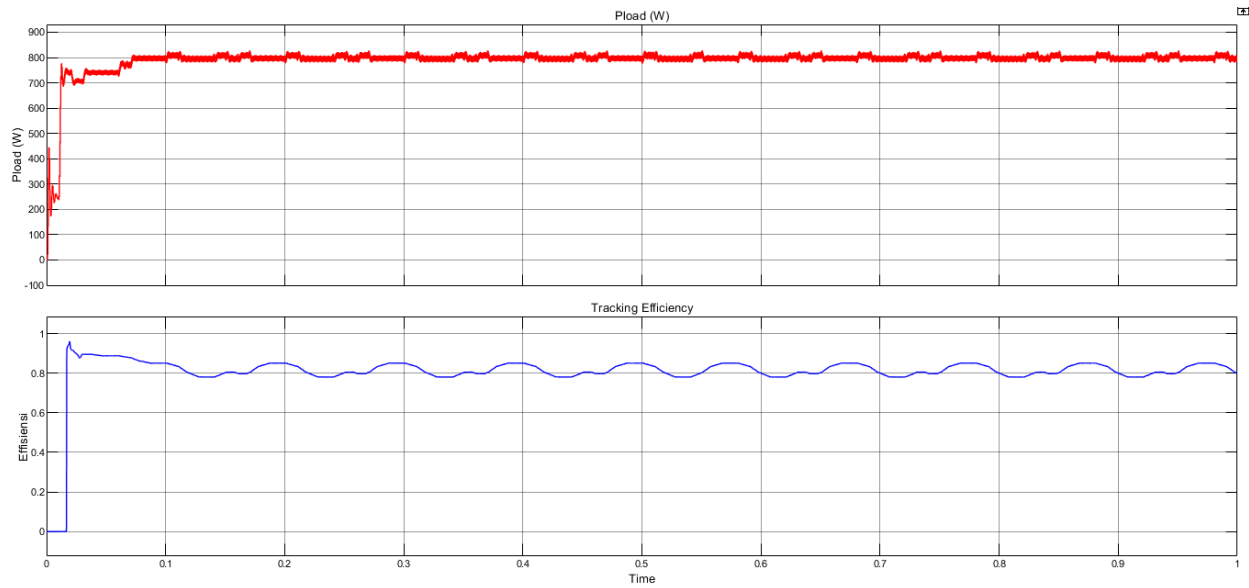

Figure 5. shows tracking efficiency

Figure 6. Therefore, it validates that the implementation of the P&O MPPT in the Simulink environment achieves both fast response and high efficiency at standard irradiance, making it a robust approach prior to PLC-based monitoring system integration.

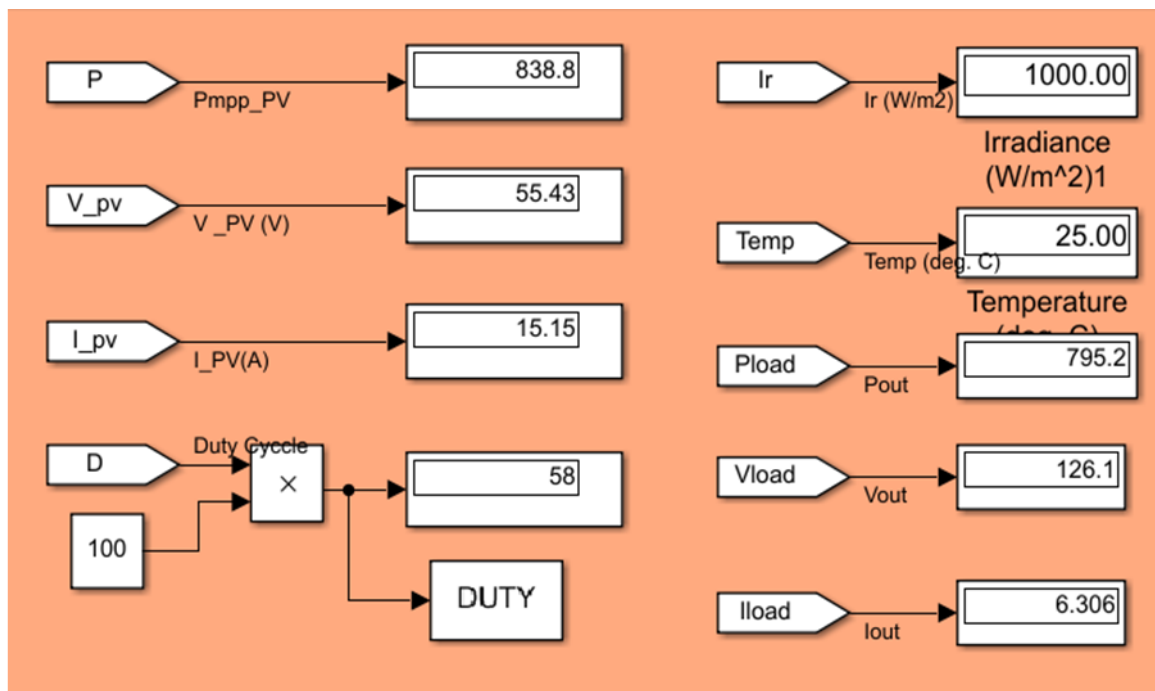

Figure 6. Shows All off Simulation Results

$$P_{mpp} = 2 \text{ series} \times 2 \text{ parallel} \times 213,15 \text{ W}$$

$$P_{mpp} = 852.6 \text{ W}$$

Figure 6 illustrates the simulation results of the 2S2P PV array at 1000 W/m<sup>2</sup> and 25 °C. The system successfully reaches its theoretical maximum power of about 852.6 W, consistent with the

module rating (213.15 W per module). The voltage, current, and power curves demonstrate stable performance after convergence, while tracking efficiency quickly approaches nearly 100%. This confirms that the optimized P&O MPPT with the boost converter can effectively extract maximum power under standard test conditions, validating the accuracy of the proposed model and algorithm. To further assess MPPT performance, additional simulations were conducted at varying irradiance levels, with the temperature fixed at 25 °C. **Figure 7** shows the PV system response without the P&O algorithm, in which the system fails to remain at the maximum power point during irradiance changes. Consequently, the extracted power falls well below the theoretical maximum, resulting in reduced efficiency and unstable output.

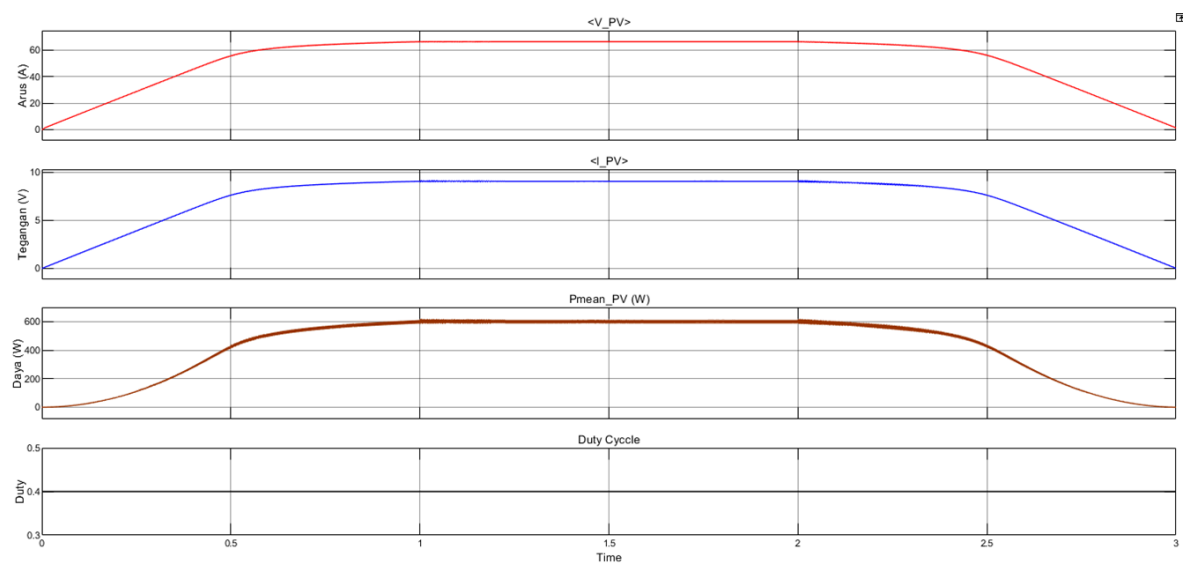

**Figure 7.** The PV Output Response without Applying the P&O algorithm

**Figure 8** illustrates the system response when the Perturb and Observe (P&O) MPPT algorithm is applied under the same irradiance variations. The results clearly demonstrate that the algorithm can dynamically adjust the boost converter's duty cycle to track the maximum power point. The output power closely follows the theoretical maximum across all irradiance levels, while the system voltage and current remain stable after short transient responses.

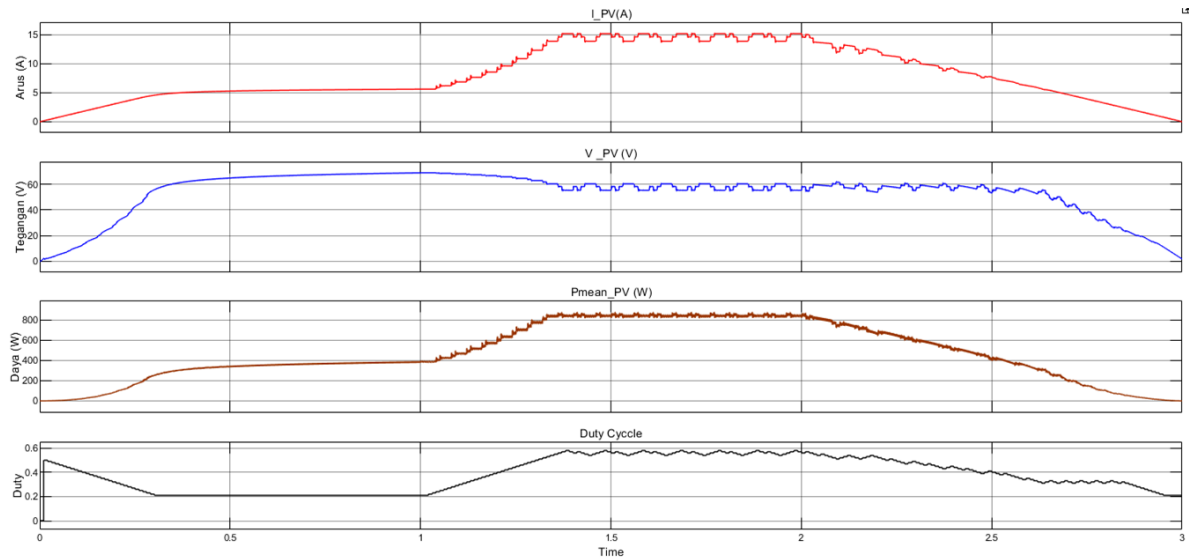

**Figure 8.** the PV output response without applying the P&O algorithm

**Figure 9** presents the simulation results of tracking efficiency under several irradiance variations at a constant temperature of 25 °C. Efficiency is calculated as the ratio between the extracted power by the MPPT-controlled boost converter and the theoretical maximum power of the PV array. The results show that the Perturb and Observe (P&O) algorithm achieves high efficiency across different irradiance levels, with only minor oscillations observed during transient periods. At standard irradiance (1000 W/m<sup>2</sup>), the efficiency quickly converges to nearly 100%, while at lower irradiance conditions the algorithm is still able to maintain efficiency above 95%.

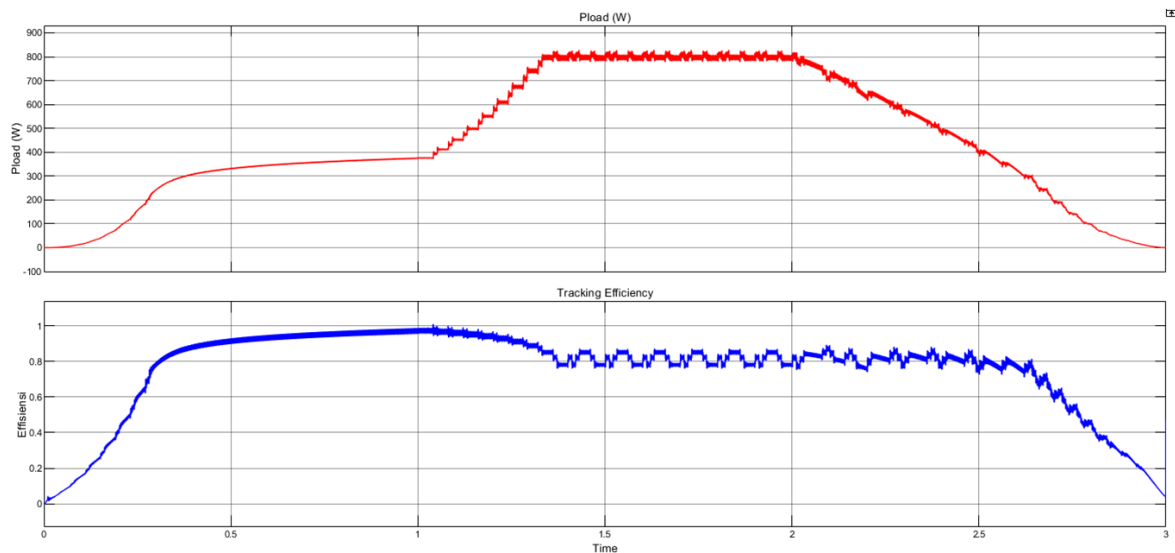

**Figure 9.** The Simulation Results of Tracking Efficiency Under Several Irradiance Variations

#### 4. Conclusion

This study optimized the Perturb and Observe (P&O) algorithm for MPPT in a PV array system with a DC–DC boost converter, modeled in MATLAB/Simulink as a 2S2P configuration of 1Soltech 1STH-215-P modules (852.6 W). The results show that the optimized P&O improves tracking efficiency, minimizes oscillations, and ensures stable operation under varying irradiance. At 1000 W/m<sup>2</sup> and 25 °C, the system achieved near 100% efficiency, closely following the theoretical maximum power. These findings confirm the robustness of the proposed method and provide a basis for future PLC-based monitoring integration and hardware implementation. Future work will include hardware prototyping and real-time implementation using a PLC-based monitoring platform to validate simulation results under real environmental conditions.

#### 5. Acknowledgement

The authors gratefully acknowledge the support from the Ministry of Education, Culture, Research, and Technology of the Republic of Indonesia (Kemendikristek) through the Directorate of Research and Community Service (DPPM), which provided funding under the research grant scheme. This support played a vital role in the successful completion of this study.

#### References:

- [1] I. Ait Ayad, E. Elwarraki, and M. Baghdadi, "Intelligent Perturb and Observe Based MPPT Approach Using Multilevel DC-DC Converter to Improve PV Production System," *Journal of Electrical and Computer Engineering*, vol. 2021, pp. 1–13, Feb. 2021, doi: 10.1155/2021/6673022.
- [2] G. C. Mahato, T. Roy Choudhury, and B. nayak, "Study of MPPT and FPPT: A Brief Comparison," in *2020 IEEE 17th India Council International Conference (INDICON)*, IEEE, Dec. 2020, pp. 1–7. doi: 10.1109/INDICON49873.2020.9342374.
- [3] I. Y. Fawzy, Y. S. Mohamad, E. G. Shehata, and M. Abd El Sattar, "A MODIFIED PERTURB AND OBSERVE TECHNIQUE FOR MPPT OF INTGRATED PV SYSTEM USING DC-DC BOOST CONVERTER," *Journal of Advanced Engineering Trends*, vol. 40, no. 1, pp. 63–77, Jan. 2021, doi: 10.21608/jaet.2021.82231.
- [4] Z. Ali, S. Abbas, A. Mahmood, S. Ali, S. Javed, and C.-L. Su, "A Study of a Generalized Photovoltaic System with MPPT Using Perturb and Observer Algorithms under Varying Conditions," *Energies (Basel)*, vol. 16, no. 9, p. 3638, Apr. 2023, doi: 10.3390/en16093638.
- [5] A. B. Djilali, A. Yahdou, H. Benbouhenni, A. Alhejji, D. Zellouma, and E. Bounadja, "Enhanced perturb and observe control for addressing power loss under rapid load changes using a buck–boost converter," *Energy Reports*, vol. 12, pp. 1503–1516, Dec. 2024, doi: 10.1016/j.egyr.2024.07.032.
- [6] Y. Ouberri, H. Yatimi, and E. Aroudam, "Modeling and Simulation of PV Module using Industrial Automation PLC," in *2019 5th International Conference on Optimization and Applications (ICOA)*, IEEE, Apr. 2019, pp. 1–7. doi: 10.1109/ICOA.2019.8727668.

- [7] A. Harrison, E. M. Nfah, J. de Dieu Nguimfack Ndongmo, and N. H. Alombah, "An Enhanced P&O MPPT Algorithm for PV Systems with Fast Dynamic and Steady-State Response under Real Irradiance and Temperature Conditions," *International Journal of Photoenergy*, vol. 2022, pp. 1–21, Nov. 2022, doi: 10.1155/2022/6009632.
- [8] A. Raj and R. P. Praveen, "Highly efficient DC-DC boost converter implemented with improved MPPT algorithm for utility level photovoltaic applications," *Ain Shams Engineering Journal*, vol. 13, no. 3, p. 101617, May 2022, doi: 10.1016/j.asej.2021.10.012.
- [9] O. O. Apeh, E. L. Meyer, and O. K. Overen, "Modeling and experimental analysis of battery charge controllers for comparing three off-grid photovoltaic power plants," *Heliyon*, vol. 7, no. 11, p. e08331, Nov. 2021, doi: 10.1016/j.heliyon.2021.e08331.
- [10] H. Hussein, A. Mahdi, and T. Abdul-Wahhab, "Design of a Boost Converter with MPPT Algorithm for a PV Generator Under Extreme Operating Conditions," *Engineering and Technology Journal*, vol. 39, no. 10, pp. 1473–1480, Oct. 2021, doi: 10.30684/etj.v39i10.1888.
- [11] S. Jana, N. Kumar, R. Mishra, D. Sen, and T. K. Saha, "Development and implementation of modified MPPT algorithm for boost converter-based PV system under input and load deviation," *International Transactions on Electrical Energy Systems*, vol. 30, no. 2, Feb. 2020, doi: 10.1002/2050-7038.12190.
- [12] K. Ullah, M. Ishaq, F. Tchier, H. Ahmad, and Z. Ahmad, "Fuzzy-based maximum power point tracking (MPPT) control system for photovoltaic power generation system," *Results in Engineering*, vol. 20, p. 101466, Dec. 2023, doi: 10.1016/j.rineng.2023.101466.
- [13] N. Van Tan, N. B. Nam, N. H. Hieu, L. K. Hung, M. Q. Duong, and L. H. Lam, "A Proposal for an MPPT Algorithm Based on the Fluctuations of the PV Output Power, Output Voltage, and Control Duty Cycle for Improving the Performance of PV Systems in Microgrid," *Energies (Basel)*, vol. 13, no. 17, p. 4326, Aug. 2020, doi: 10.3390/en13174326.
- [14] S. Da'na, A. Sagahyoon, A. Elrayes, A. R. Al-Ali, and R. Al-Aydi, "Development of a monitoring and control platform for PLC-based applications," *Comput Stand Interfaces*, vol. 30, no. 3, pp. 157–166, Mar. 2008, doi: 10.1016/j.csi.2007.08.008.
- [15] S. Amely Jumaat *et al.*, "Monitoring of PV Performance Using LabVIEW," *Indonesian Journal of Electrical Engineering and Computer Science*, vol. 12, no. 2, p. 461, Nov. 2018, doi: 10.11591/ijeecs.v12.i2.pp461-467.
- [16] K. Krishnam, T. S. Padmanabhan, F. Alsaif, and S. Senthilkumar, "Performance optimization of interleaved boost converter with ANN supported adaptable stepped-scaled P&O based MPPT for solar powered applications," *Sci Rep*, vol. 14, no. 1, p. 8115, Apr. 2024, doi: 10.1038/s41598-024-58852-8.
- [17] A. Majeed Shaikh, M. Fawad Shaikh, S. Ahmed Shaikh, M. Krichen, R. Ali Rahimoon, and A. Qadir, "Comparative analysis of different MPPT techniques using boost converter for photovoltaic systems under dynamic shading conditions," *Sustainable Energy Technologies and Assessments*, vol. 57, p. 103259, Jun. 2023, doi: 10.1016/j.seta.2023.103259.
- [18] S. A. Krim, F. Krim, H. Afghoul, and F. Abdelmalek, "An Enhanced Perturb and Observe MPPT for Photovoltaic Systems Based on Fuzzy Step," *Journal Européen des Systèmes Automatisés*, vol. 57, no. 2, pp. 363–372, Apr. 2024, doi: 10.18280/jesa.570206.
- [19] L. Prasetyani, M. J. F. Arifianto, D. Subagio, W. Sarfat, and Aprilyanto, "Experimental Analysis Design of Solar Panel Energy Monitoring Prototype," in *7th International Conference on Information Technology, Computer, and Electrical Engineering, ICITACEE 2020 - Proceedings*, 2020. doi: 10.1109/ICITACEE50144.2020.9239166.
- [20] L. Prasetyani, A. D. Dini, and E. S. Ma'Arif, "Automation Control Design of An Storage Machine Based on Omron PLC System," in *2021 8th International Conference on Information*

*Technology, Computer and Electrical Engineering, ICITACEE 2021*, 2021. doi: 10.1109/ICITACEE53184.2021.9617469.

- [21] A. M. Noman, H. S. Sheikh, A. F. Murtaza, S. Z. Almutairi, M. H. Alqahtani, and A. S. Aljumah, "Maximum Power Point Tracking Algorithm of Photo-Voltaic Array through Determination of Boost Converter Conduction Mode," *Applied Sciences*, vol. 13, no. 14, p. 8033, Jul. 2023, doi: 10.3390/app13148033.
- [22] M. Ahmad, A. Numan, and D. Mahmood, "A Comparative Study of Perturb and Observe (P&O) and Incremental Conductance (INC) PV MPPT Techniques at Different Radiation and Temperature Conditions," *Engineering and Technology Journal*, vol. 40, no. 2, pp. 376–385, Feb. 2022, doi: 10.30684/etj.v40i2.2189.